

Slate

Kitchen Mixer

Article no.: 650667400
Finish: Chrome/Black
Series: Slate

EAN no.: 5708516830610



Standard features:

- 1 handle
- 120° swivel limitation
- Ceramic cartridge
- Cold-start
- Rub-clean aerator
- Scalding protection (38°C)
- Water consumption max. 8 l/min
- Eco-Save water saving feature

Product features

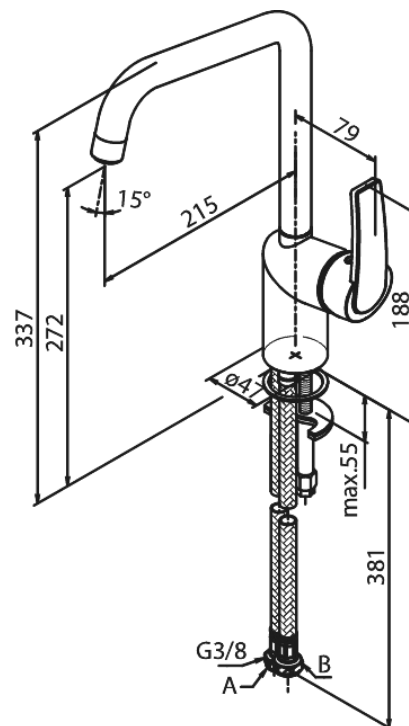

FM Mattsson Denmark ApS
Hvidkærvej 48, 5250 Odense SV, DK-56416218

+45 88 33 00 34 damixa-international@fmm-mora.com

Mere information på damixa.com

damixa